

FS2207L**Advanced Wireless Audio Transmitter/Receiver Module**

Features

- An advanced and robust 48KHz 16-bit 2 channels uncompressed digital audio via FreeSpan™ RF core technology
- 2.4GHz GFSK wireless link with 8 selectable channels
- Supports 48Kps I²S, SPDIF format (IEC 61937)
- Integrated baseband processor with
 - Advanced ECC with low latency
 - Advanced anti-interference engine
 - Jitter reduction management
 - System power management
 - Receiver auto-scanning support
 - Virtual keys support
- 3.3V supply
- Lower power consumption
- Audio Latency (12ms ~ 40ms)
- Sleep mode / Standby mode
- Headphone/Speaker Mode Control
- Up to 30m indoor range
- Compact in size
- Highly integrated , Low BOM cost
- Lead Free and RoHS compliant.

Contact Information**FreeSystems Pte Ltd**

Singapore Office
28 Ayer Rajah Crescent, #02-01A,
Ayer Rajah Industrial Estate
Singapore 139959
Tel +65 6773 7605 / 6773 7608
Fax +65-6778-8226

Taiwan Branch Office
9F-1, No. 25, Puding Road,
Hsinchu 300, Taiwan, R.O.C.
Tel +886-3-578-1670
Fax +886-3-578-1650

Website: www.freesystems.com.sg

Email: sales@freesystems.com.sg

General Description

FS2207L Module set is a pair of compact modules which comprise the baseband and the RF device. 2-channel of audio signals can be transmitted across a robust radio frequency link.

The analog front ends can be designed according to application needs on a separate board onto which the FS2207L modules can be mounted.

FS2207L module demonstrates the robustness of RF digital audio transmission that minimizes the effect of RF interference, multipath / fading using various techniques such as:

- Advanced Antenna Diversity
- Powerful Forward Error Correction algorithm
- Multi-channels selection and auto channel locking mechanism
- Advanced Patent Pending Anti-interference Algorithms
- Advanced Muting Algorithms

FS2207L module can support 2.4GHz 10dBm power. A typical 10dBm RF system can cover up to 30 meters transmission range in indoor environment. With additional PA, the transmission power can be further increased.

The module provides in-situ EEPROM programming via connector interface to the parallel port of PC operating under windows OS system.



FS2207L

Advanced Wireless Audio Transmitter/Receiver Module

Block Diagrams

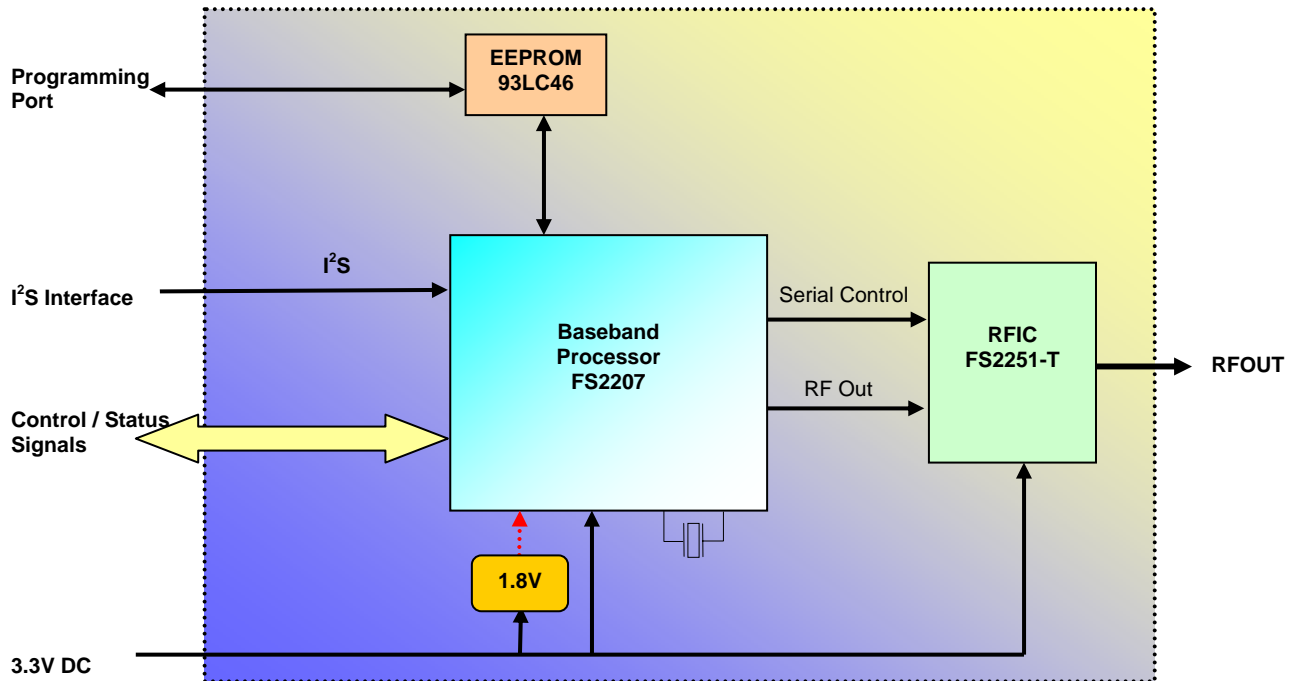

Transmitter Module Block Diagram

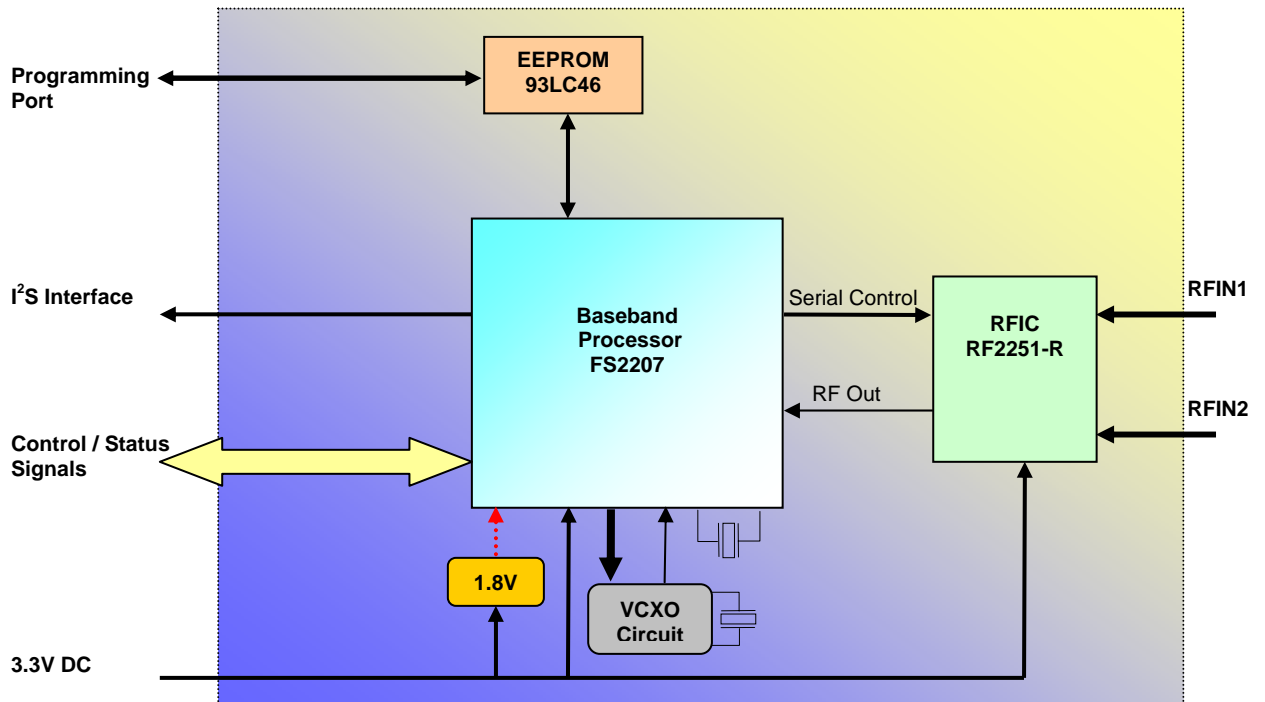

Receiver Module Block Diagram

FS2207L**Advanced Wireless Audio Transmitter/Receiver Module**

Benefits

- **Proven solution** → low risk
- **Cost effective solution** → reducing time to market.
- **“Drop-in” modular design** → easy integration.
- **Low power** → ideal for battery powered applications
- **Small form factor** → save space and material cost
- **Low Latency** → support Dolby/DTS format transmission
- **Broadcast mode** → support multiple receivers or headsets.

FreeSystem Advantages

FreeSystems has vast experience in developing RF and Baseband ICs as well as designing full wireless audio systems. With know-how in RF technologies, Digital Signal Processing and audio processing algorithms, FreeSystems has developed a unique set of core competencies in

- RF, Antenna design and EMI Optimization
- System Architecture and Design
- Signal Processing
- Design for Manufacturing

Typical advantages of FreeSystems products include:

- High quality mass production capability
- Industry endorsed **Freespan™** core technology
- Support for all current and emerging international standards.

About FreeSystems

FreeSystems Pte Ltd was incorporated in June 1999. The company provides both Infra Red and RF wireless digital audio solutions. FreeSystems has strong IP portfolio of more than 48 patents filed, issued or pending worldwide. Over the years, FreeSystems has also demonstrated the capability and capacity to support major CE customers and technology partners in rapid product realization.